

MAQI

零件样本

美和缝纫机

零件手册使用说明

- 1、本手册使用于封面上所示同种系列的缝纫机；
- 2、部分零件设计上的改变不预先通知用户；
- 3、用 [] 标注部分属于组件部分。

Notes for using this parts book

- 1.This book is applicable to sewing machines which have the same plate number as shown on the cover of this book(or correction sheet).
- 2.Parts are subject to changes in design without prior notice.
- 3.Parts supplied as complete assemblies are circled by a dotted line [] .

目 录

CONTENTS

1. 机壳分组件 Machine frame&miscellaneous cover components	1
2. 上轴、轴套分组件 Main shaft&thread take-up components	4

1、机壳分组件 MACHINE RRAME&MISCELLANEOUS COVER COMPONENTS

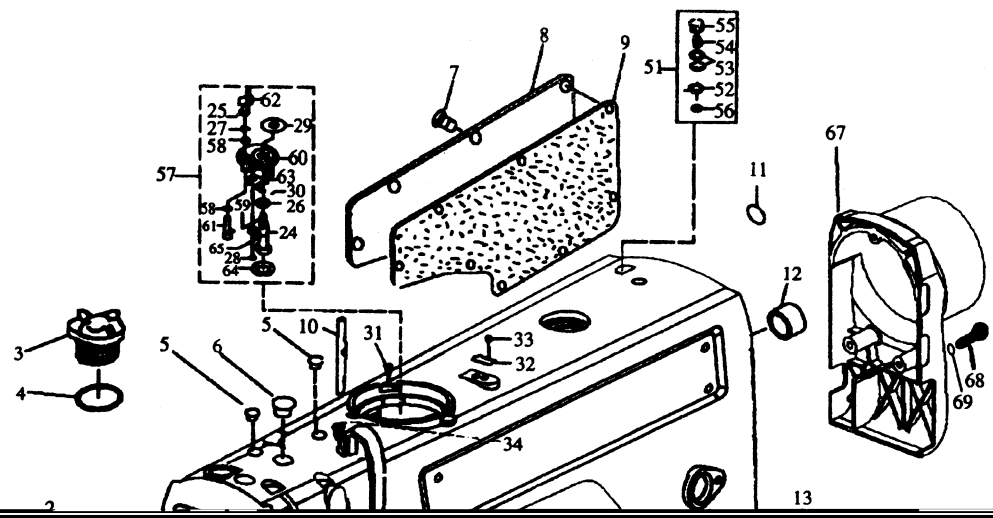

1、机壳分组件 MACHINE RRAME&MISCELLANEOUS COVER COMPONENTS

序号 Ref.No.	名 称	Description	数量 QTY
1	面板	FACE PLATE	1
2	面板垫	FACE PLATE GASKET	1
3	油窗	OIL WINDOW	1
4	油窗O形圈	THRUST COLLAR ASM.	1
5	挑线连杆销螺孔塞	RUBBER PLUG	2
6	针杆曲柄螺孔塞	RUBBER PLUG	1
7	后窗板螺钉	SCREW 3/16-28 L=9	8
8	后窗板	SIDE PLATE	1
9	后窗板垫	SIDE PLATE GASKET	1
10	过线柱	NEEDLE THREAD GUIDE PIN	1
11	接地指示牌	EARTHING INDICATION PLAT	1
12	送料调节器孔塞	RUBBER PLUG	1
13	下轴盲孔塞	RUBBER PLUG	1
14	型号牌	MODEL PLATE	1
15	底板支柱	BED SCREW STUD	2
16	电线过线套	NEEDLE BEARING	1
17	电线夹	CORD HOLDER	1
18	电线夹螺钉	SCREW	1
19	电线压板	CORD HOLDER	1
20	底板支柱(长)	BED SCREW STUD	1
21	底板支柱(中)	BED SCREW STUD	1

2、上轴、挑线分组件 Main shaft & thread take-up components

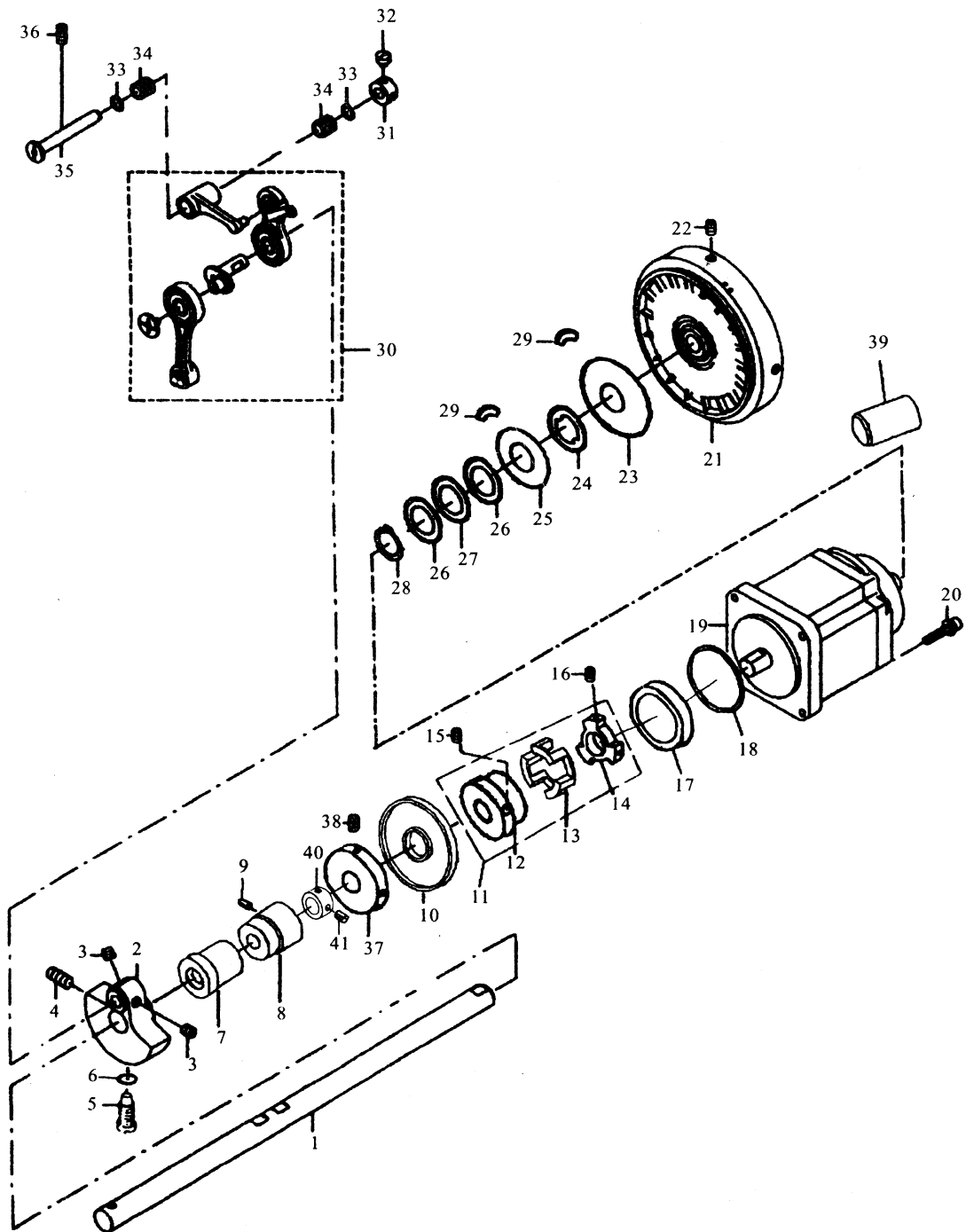

2、上轴、挑线分组件 MAIN SHAFT & THREAD TAKE-UP COMPONENTS

序号 Ref.No.	名 称	Description	数 量 QTY
---------------	-----	-------------	------------

3、针杆、夹线分组件 Needle bar & thread tension components

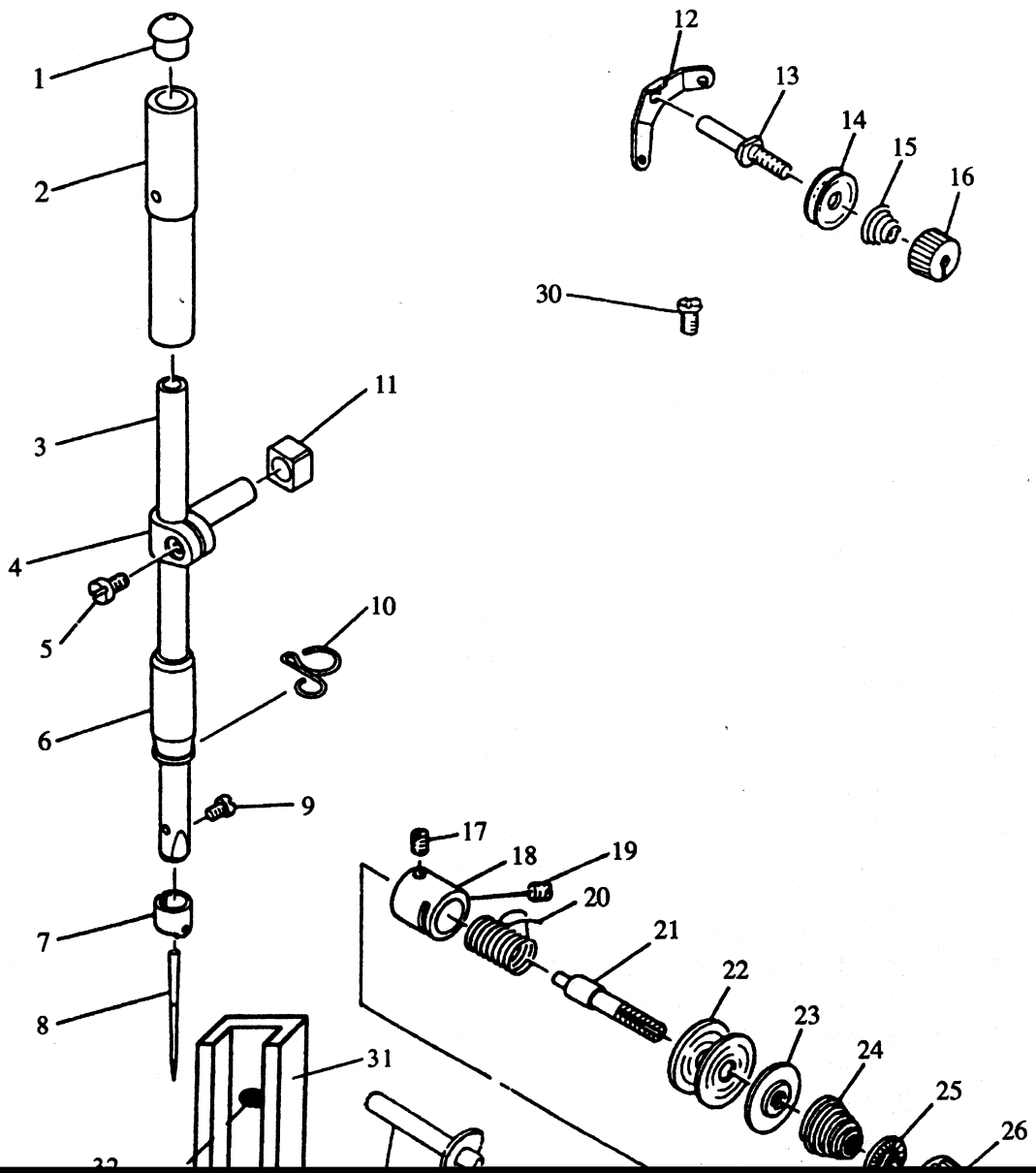

3、针杆、夹线分组件 NEEDLE BAR & THREAD TENSION COMPONENTS

序号		数量
----	--	----

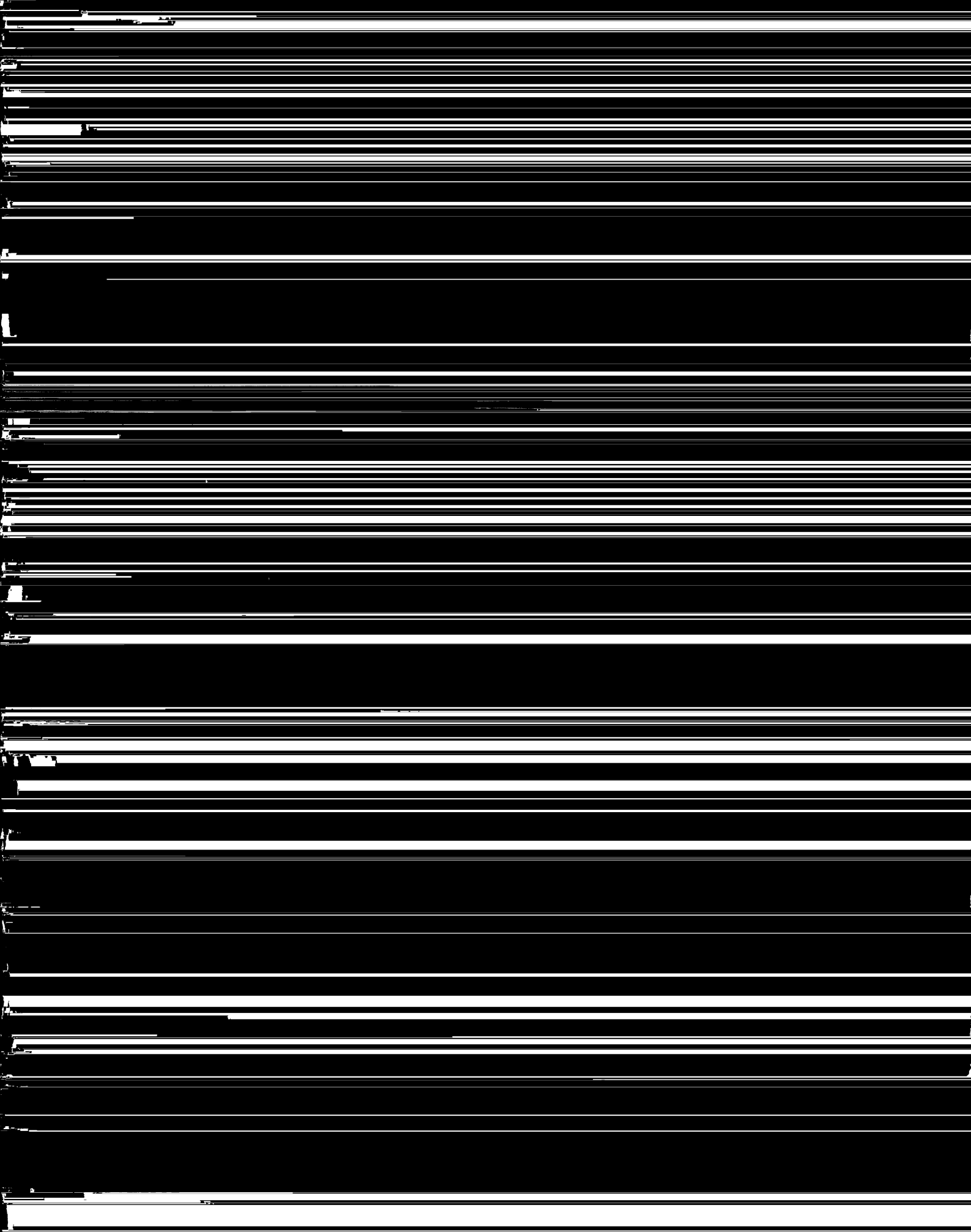

4、压料、松线分组件 Presser bar & tensiob release components

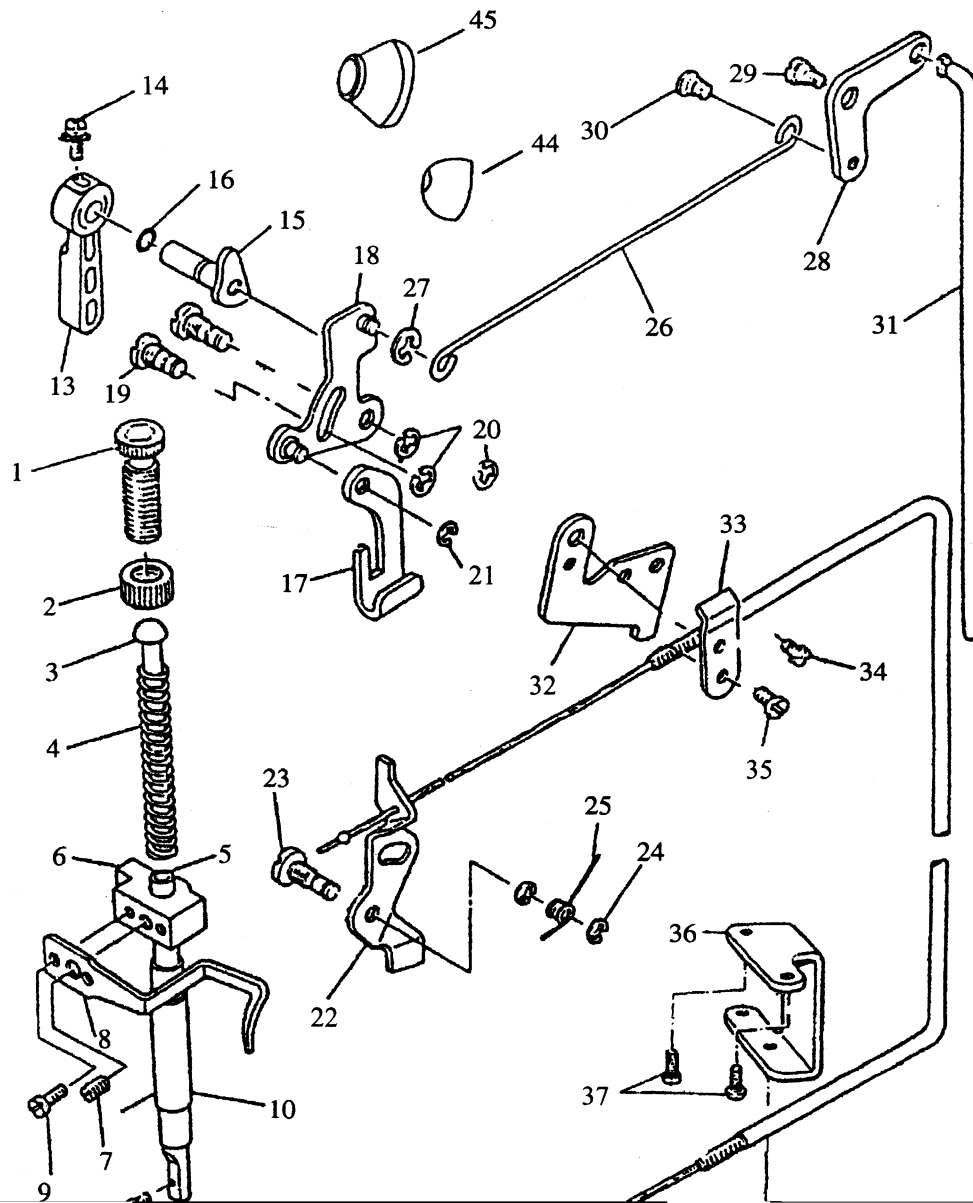

4、压料、松线分组件 PRESSER BAR & TENSIOB RELEASE COMPONENTS

序号 Ref.No.	名 称	Description	数量 QTY
1	调压螺钉	PRESSER SPRING REGULATOR	1
2	调压螺母	NUT 1/2-28	1
3	调压导杆	PRESSER GUIDE BAR	1
4	调压簧	PRESSER SPRING	1
5	压杆	PRESSER GUIDE BAR	1
6	压杆导架	NEDDLE BAR GUIDE BRACKET	1
7	压杆导架螺钉	SCREW 1/4-40 L=8	1
8	缓线调节钩	PRESSER BAR GUIDE BRACKET	1
9	缓线调节钩螺钉	SCREW 9/64-40 L=8.5	2
10	压杆轴套	PRESSER BAR BUSHING LOWER	1
11	活压脚部件	PRESSER FOOT ASM	1
12	活压脚螺钉	SCREW 9/64-40 L=9.5	1
13	压脚扳手	HAND LOFTER	1
14	压脚扳手螺钉	SCREW 9/64-40 L=8.5	1
15	压脚扳手凸轮部件	HAND LOFTER CAM ASM.	1
16	压脚扳手轴O形圈	RUBBER RING	1
17	压脚升降板	LIFTING LEVER	2
18	抬压脚前杠杆部件	HAND LIFTER LINK ASM.	1
19	前杠杆螺纹销	LINK SHAFT	2
20	螺纹销开口挡圈	SNAP RING	4
21	升降板连接特制开口挡圈	LIFTING LEVER RING	1
22	松线顶板	TENSION RELEASE PLATE	1
23	松线顶板螺纹销	TENSION RELEASE SHAFT	1
24	螺纹销开口挡圈	SNAP RING	1
25	松线顶板复位簧	TENSION RELEASE RETURN SPRING	1
26	抬压脚拉杆	LIFTING LEVER CONNECTING ROD	1
27	拉杆挡圈	SNAP RING	1
28	抬压脚后杠杆	LIFTING LEVER LINK	1
29	后杠杆轴位螺钉	HINGE SCREW	1
30	抬压脚拉杆螺钉	HINGE SCREW	1
31	抬压脚顶杆	CONNECTING ROD VERRICAL	1
32	软管支承板	WIRE HOLDER BRACKET (UPPER)	1
33	软管压板	WIRE HOLDER	1
34	软管支承板螺钉	SCREW 3/16-28 L=6	1
35	软管压板螺钉	SCREW 11/64-40 L=7	1
36	松线钢绳座	LOOSING LINE PLATE	1
37	松线钢绳座螺钉	SCREW	1
38	钢绳固定板	FIXING SHUTTER	1
39	钢绳固定板螺钉	SCREW	1
40	松线钢丝组件	LOOSING LINE ASM.	1
41	松线钢丝调节螺母	NUT	2
42	松线座	LOOSING PLATE	1
43	松线复位弹簧	SPRING	1
44	松线钢丝挡块	BEFFLE	1
45	压杆油封	PRESSER BAR OIL SEAL	1

5、勾线分组件 Hook of driving shaft components

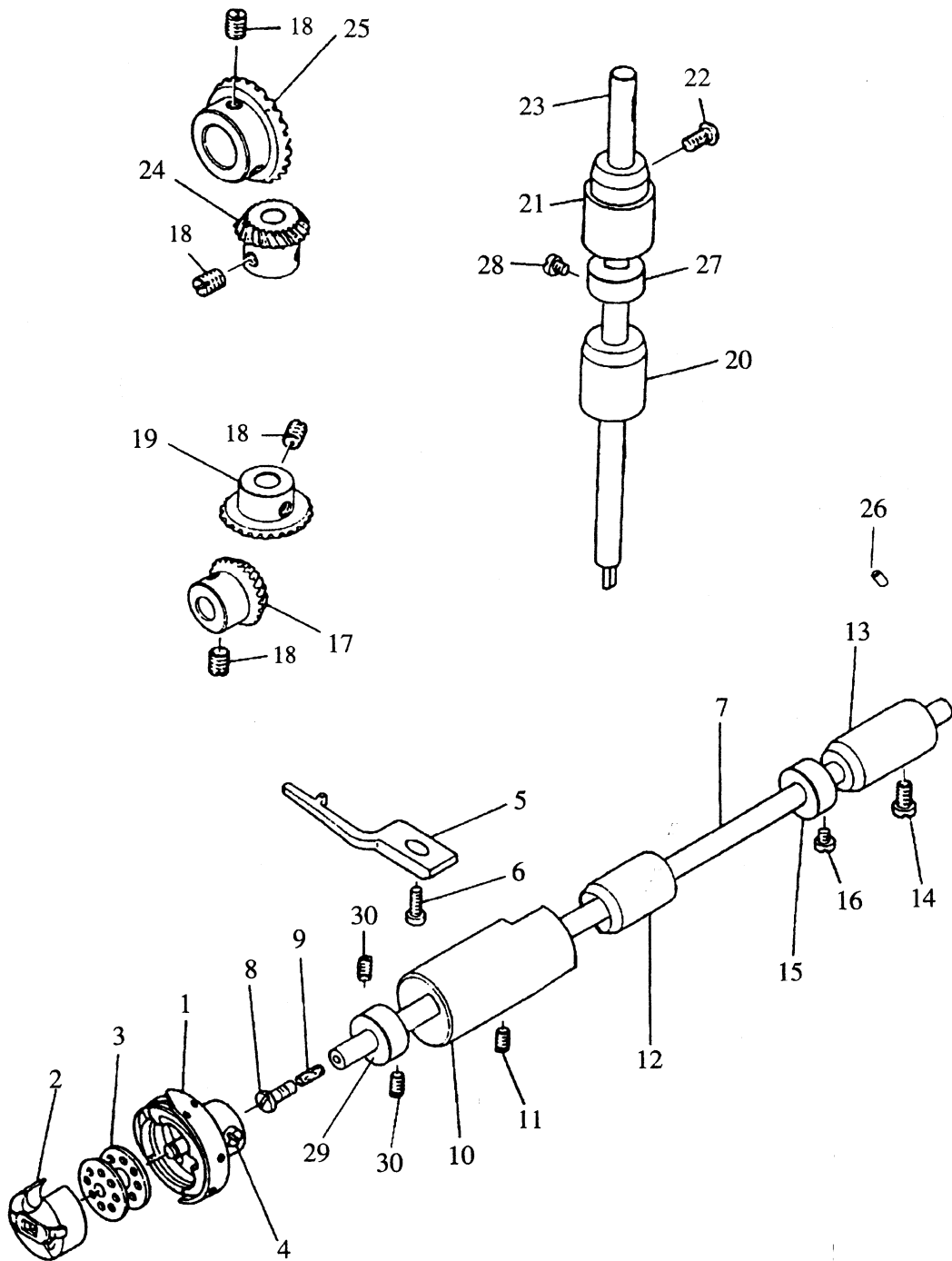

5. 勾线分组件 HOOK OF DRIVING SHAFT COMPONENTS

序号 Ref.No.	名 称	Description	数 量 QTY
1	旋梭	HOOK ASM.	1
2	梭子	BOBBIN CASE ASM.	1
3	梭心	BOBBIN	1
4	旋梭紧固螺钉	SCREW	2
5	旋梭定位钩	POSTIONING FINGER	1
6	旋梭定位钩螺钉	SCREW 11/64-40 L=9.5	1
7	下轴	HOOK DRIVING SHAFT	1
8	下轴限油螺钉	OIL SEAL SCREW ASM.	1
9	下轴限油芯	OIL WICK	1
10	下轴前轴套	BUSHING ASM. FRONT	1
11	下轴前轴套螺钉	SCREW 15/64-28 L=7.5	1
12	下轴中轴套	BUSHING MIDDLE	1
13	下轴后轴套	BUSHING REAR	1
14	下轴后轴套螺钉	SCREW 3/16-28 L=15	2
15	下轴衬套	THRUST COLL AR ASM	1

6、送料分组件 Feed mechanism components



6、送料分组件 FEED MECHANISM COMPONENTS

序号 Ref.No.	名称	Description	数量 QTY
1	送料偏心轮部件	FEED DRIVE ECCENTRIC CAM ASM.	1
2	送料偏心轮	FEED DRIVE ECCENTRIC CAM	1
3	送料偏心轮螺钉	SCREW 1/4-40 L=11	2
4	送料偏心轮盖板	THRUST COLLAR	1
5	偏心轮盖板螺钉	SCREW 9/64-40 L=5	2
6	送料连杆	ROCKER SHAFT CONNECTING ROD	1
7	送料连杆销	WALKING FOOT PIN	1
8	连接销螺钉	SCREW 9/64-40 L=6	4
9	送料长摆动板	WALKING FOOT LINK	2
10	送料短摆动板	CONNECTING LINK	2
11	长摆动板连接销	WALKING FOOT PIN	2
12	送料摆动板座部件	WALKING FOOT ADJUST LINK	1
13	送料摆动板座左右销	ADJUSTING LINK FULCRUM SHAFT	2
14	左右销螺钉	SCREW 15/64-28 L=7	2
15	抬牙送布轴紧圈组件	RETAINING RING ASM.	2
16	送布轴紧圈螺钉	SCREW	2
17	送料曲柄	FEED ROCKER SHAFT CRANK ASM	1

送刺 湘北八组外 五 一 一 六

7. 送料、调节分组件 FEED REGULATING COMPONENTS

序号 Ref.No.	名称	Description	数量 QTY
1	送料距旋钮螺钉	SCREW 3/16-28 L=9	1
2	送料距旋钮	FEED DIAL	1
3	送料调节螺柱O形圈	RUBBER RING	1
	送料距旋钮	FEED DIAL	1

7、送料、调节分组件 FEED REGULATING COMPONENTS

序号	名称	Description	数量
----	----	-------------	----

8.1 剪线分组件 Thread trimmer components
(旋刀组件 ROUND KNIFE COMPONENTS)

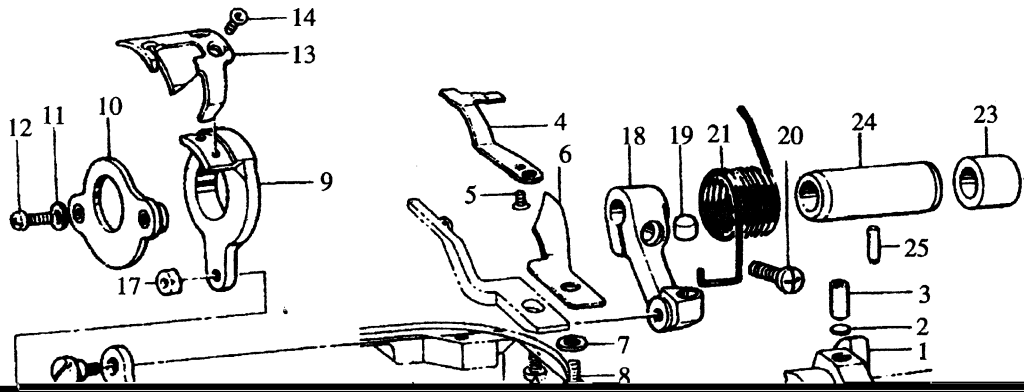

8.1 剪线分组件 THREAD TRIMMER COMPONENTS
(旋刀组件 ROUND KNIFE COMPONENTS)

序号 Ref.No.	名称	Description	数量 QTY
1	剪线凸轮	THREAD TRIMMER CAM	1
2	切线凸轮垫	CAM COLLAR	2
3	剪线凸轮螺钉	SCREW	2
4	定刀	CONNTER KNIFE	1
5	定刀固定螺钉	SCREW	1
6	分线器	DISPART THREAD SHUTTLE	1
7	分线器固定螺钉垫圈	WASHER	1
8	分线器固定螺钉	SCREW	1
9	动刀架	ROUND KNIFE BRACKET	1
10	刀架压板组件	KNIFE HOLDER ASM.	1
11	刀架压板垫圈	WASHER	2
12	刀架压板螺钉	SCREW	2
13	动刀	ROUND KNIFE	1
14	动刀固定螺钉	SCREW	2
15	刀轴连杆	KNIFE SHAFT CRANK ROD	1
16	刀轴连杆螺钉	SCREW	2
17	刀轴连杆螺母	NUT	1
18	切线驱动曲柄	TRIMMING CRANK	1
19	切线驱动曲柄止动块	BLOCK	1
20	切线驱动曲柄螺钉	SCREW	1
21	复位弹簧	REPLACE SPRING	1
22	切线驱动曲柄轴	TRIMMING CRANK SHAFT	1

8.2 剪线分组件 Thread trimmer components (平刀组件 STRAIGHT EDGE)

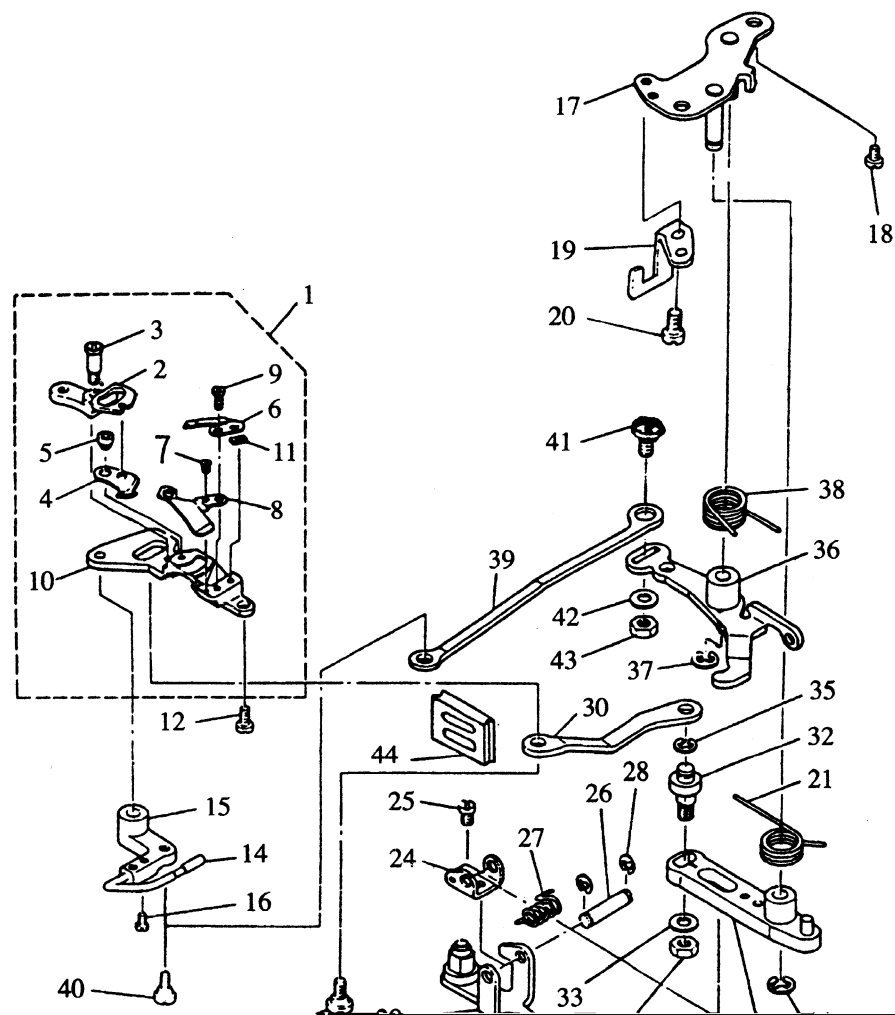

8.2 剪线分组件 THREAD TRIMMER COMPONENTS
(平刀组件 STRAIGHT EDGE)

序号 Ref.No.	名 称	Description	数量 QTY
---------------	-----	-------------	-----------

8.2 剪线分组件 THREAD TRIMMER COMPONENTS
(平刀组件 STRAIGHT EDGE)

序号 Ref.No.	名称	Description	数量 QTY
40	挡线器拉杆轴位螺钉	HINGE SCREW	1
41	挡线器拉杆连接销	PICKER LINK PIN	1
42	垫圈	WASHER	1

0 接线盒组件 Wiring components

9、拨线分组件 WIPER COMPONENTS

序号 Ref.No.	名称	Description	数量 QTY
1	拨线电磁铁支架部件	WIPER BASE ASM.	1
2	支架安装螺钉	SCREW 3/16-28 L=9	1
3	拨线器开关	POWER SOURCE SWITCH ASM	1

10、润滑分组件 Lubrication components

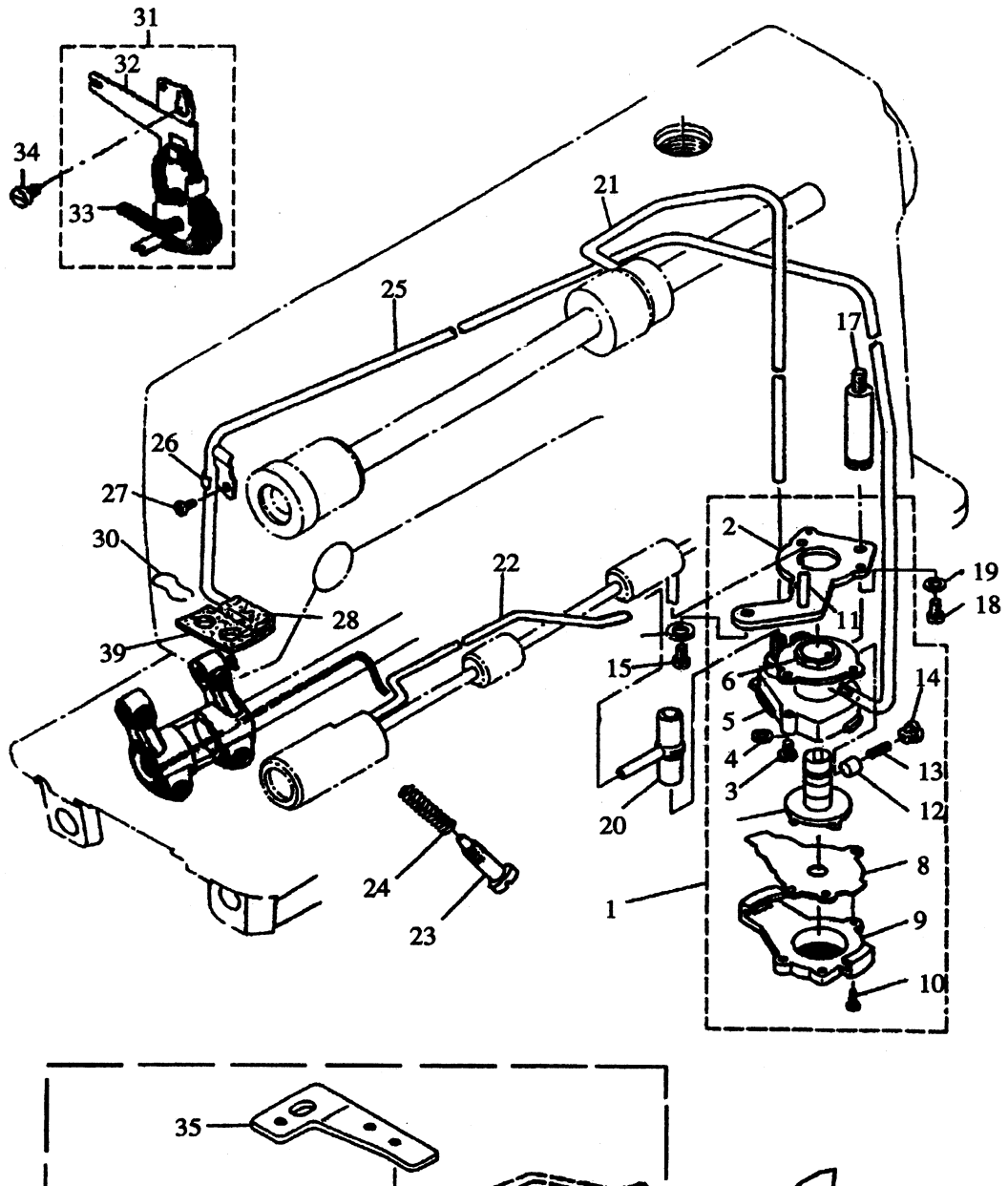

10、润滑分组件 LUBRICATION COMPONENTS

序号 Ref.No.	名 称	Description	数量 QTY
1	油泵部件	LUBRICATING OIL PUMP ASM.	1
2	油泵安装板	OIL PUMP INSTALLING BASE	1
3	油泵安装螺钉	SCREW 15/64-28 L=9	3
4	油泵安装止退垫圈	WASHER	3
5	油泵体	OIL PUMP	1
6	油泵体衬套	OIL PUMP BUSHING	1
7	油泵叶轮	OIL PUMP IMPELLER	1
8	油泵叶轮托板	OIL PUMP IMPELLER COVER	1
9	油泵盖分部件	LUBRICATING OIL PUMP COVER	1
10	油泵盖螺钉	SCREW	3
11	下轴供油管	HOOK DRIVING SHAFT OIL TUBE	1
12	回油柱塞	PLUNGER	1
13	柱塞簧	PLUNGER SPRING	1
14	柱塞螺钉	SCREW	1
15	油泵螺钉	SCREW	1
16	隔油板	OIL STOPPER ASM.	1
17	油泵连接螺柱	OIL PUMP SUPPORT	1
18	螺柱连接螺钉	SCREW 11/64-40 L=9.5	1
19	油泵连接螺柱挡圈	WASHER	1

11 油舟壓担抬压脚分组件 Presser foot components of oil plate knee lift

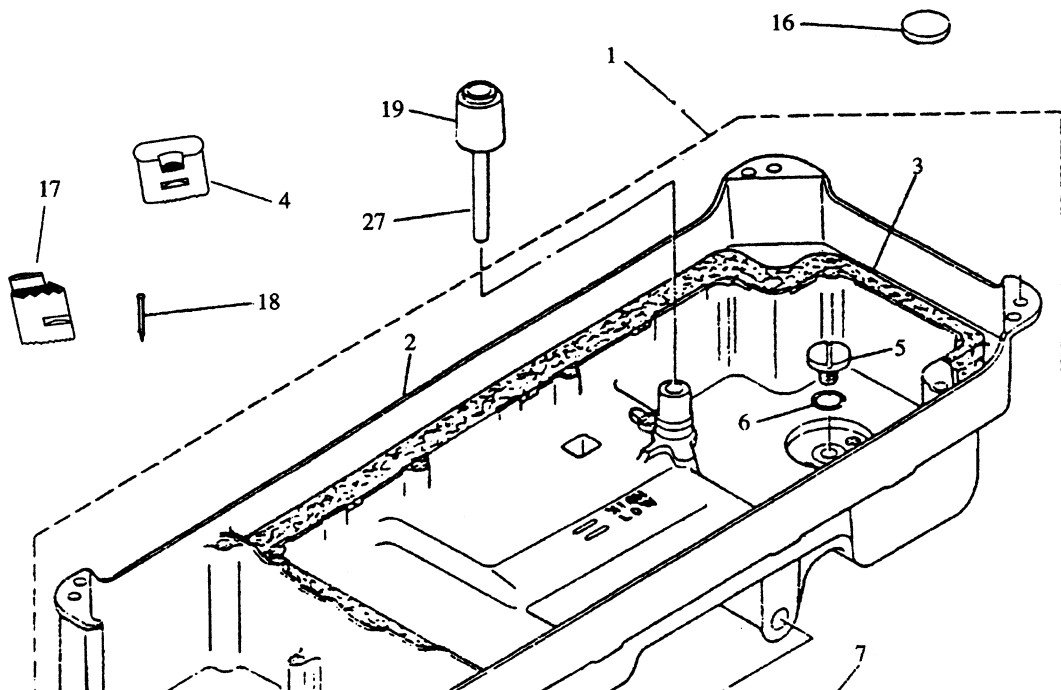

11、油盘膝提抬压脚分组件 PRESSER FOOT COMPONENTS OF OIL PLATE KNEE LIFT

序号 Ref.No.	名 称	Description	数 量 QTY
1	油盘部件	OIL PLATE COMPONENTS	1
2	油盘	OIL PLATE	1
3	油盘垫	OIL PLATE BED	1
4	机头座垫	MACHINE HEAD BED	1

12、过线架分组件 Components of thread-running stand

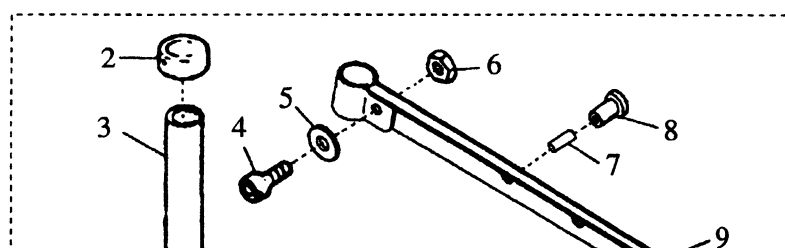

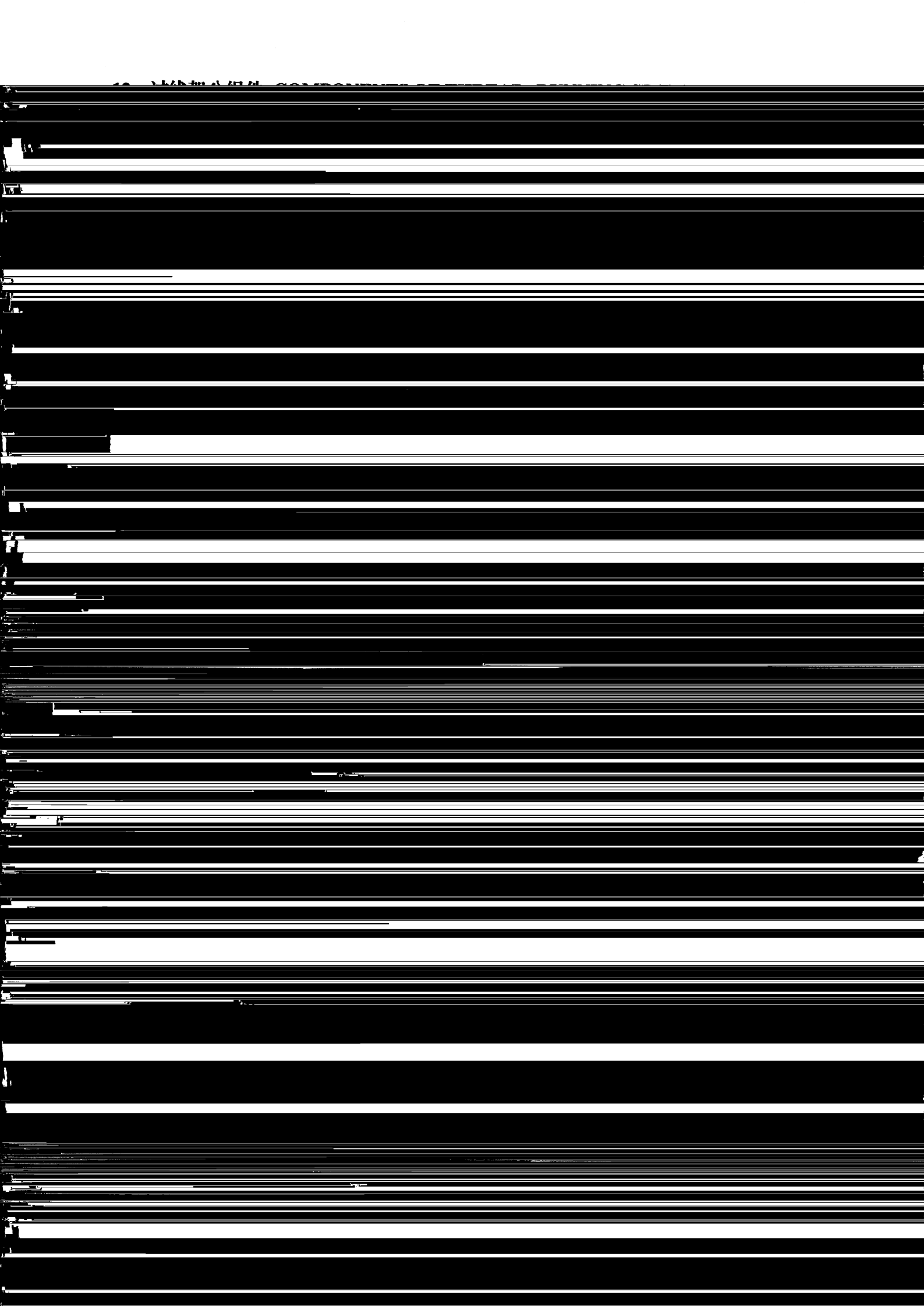

13、附件 Auxiliaries

